

Outdoor High Gain Panel Antenna

Product Number : PW-OHG-65-1710/2500

Electrical Specifications

Frequency Range	1710-2500 MHz
Gain 1710-2170Mhz	14.5 dBi
2300-2500Mhz	15.0 dBi
VSWR	< 1.4
Horizontal 3dB Beam-width	65° ± 10°
Vertical 3dB Beam-width	17° ± 4°
Front-Back Ratio	> 25dB
Polarization	Vertical
Impedance	50Ω
Maximum Input Power	200 W
Connector	N-Female with pigtail
IM.3 rd Order(2x43dBm)	<-150dBc
Lightning Protection	Direct Ground



Mechanical Specifications

Dimension (LxWxH)	700x200x65 mm
Weight of Antenna	3kg
Weight of Mounting Kits	0.5kg
Diameter of Installation Pole	Φ50mm ~65mm
Radome Material	Fiberglass
Horizontal	360°
Angle of Pitch	0 ~ -15° (Optional-for Pole Mounting)
Rated Wind Velocity	241km/h

Vertical Pattern

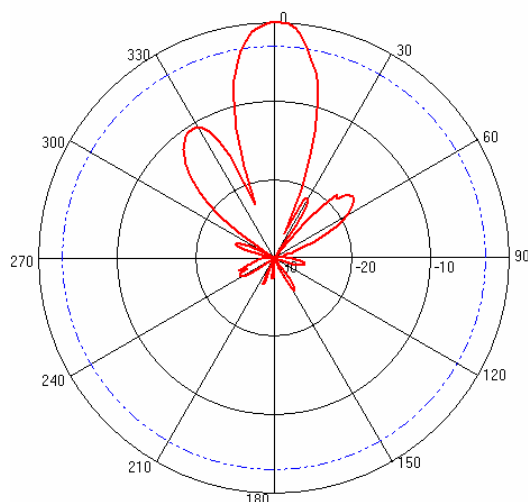

Horizontal Pattern

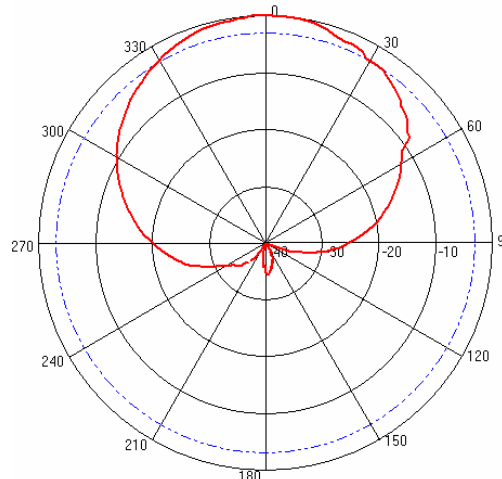

Outdoor High Gain Panel Antenna

Product Number : PW-OHG-65-1710/2700

Electrical Specifications

Frequency Range	1710-2700 MHz
Gain 1710-2170Mhz	14.5 dBi
2300-2500Mhz	15.0 dBi
VSWR	< 1.4
Horizontal 3dB Beam-width	65° ± 10°
Vertical 3dB Beam-width	17° ± 4°
Front-Back Ratio	> 25dB
Polarization	Vertical
Impedance	50Ω
Maximum Input Power	200 W
Connector	N-Female with pigtail
IM.3 rd Order(2x43dBm)	<-150dBc
Lightning Protection	Direct Ground



Mechanical Specifications

Dimension (LxWxH)	700x200x65 mm
Weight of Antenna	3kg
Weight of Mounting Kits	0.5kg
Diameter of Installation Pole	Φ50mm ~65mm
Radome Material	Fiberglass
Horizontal	360°
Angle of Pitch	0 ~ -15° (Optional-for Pole Mounting)
Rated Wind Velocity	241km/h

Vertical Pattern

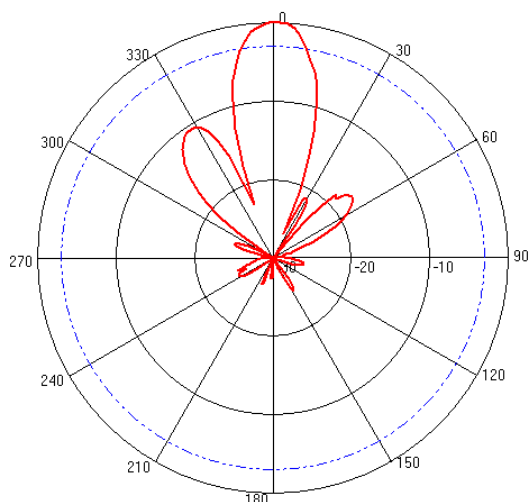

Horizontal Pattern

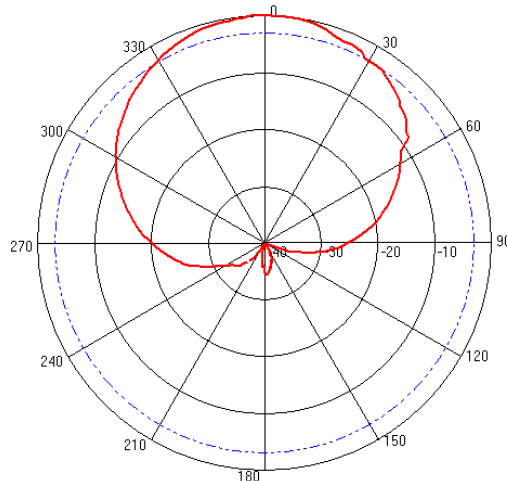

Installation guide

Product Number : PW-OHG-65-1710/2500 or PW-OHG-65-1710/2700

There are two optional installation methods available for this antenna.

Method a. (Wall mounting Fig.1)

1. Bore six $\phi 8 \times 25$ holes on the wall and insert accessories 3 in these holes.
2. Fix accessories 2 on the wall with bolts.
3. Install the antenna on the accessories 2 on the wall.
4. Connect the cable with the antenna.

Method b. (pole mounting Fig.2)

1. Fix the clamp on the antenna with four bolts to the antenna.
2. Install the antenna on the pole.
3. Adjust the tilt angle of the antenna and tighten all nuts.

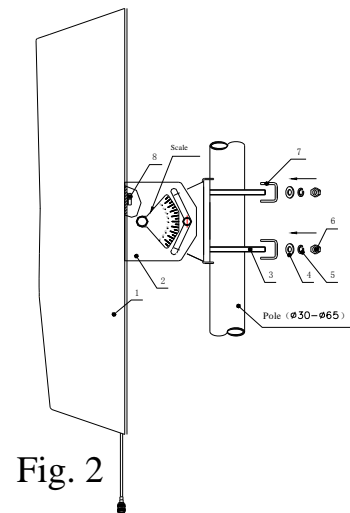
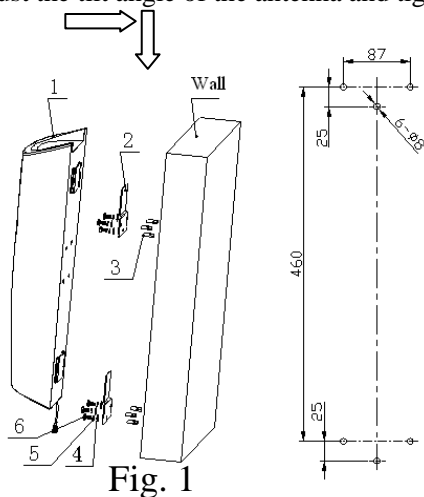

Accessories list:

No.	Name	Quantity	
For wall mounting			
1	Antenna	1	
2	Fix board	2	
3	Dilatants	6	Stainless steel
4	Plat washer - A6	6	Stainless steel
5	Spring washer 6	6	Stainless steel
6	Bolts M6×16	6	Stainless steel
For pole mounting			
7	TXJ-A-3	1	
8	Bolts M8×100	4	Stainless steel
9	Plat washer - A8	8	Stainless steel
10	Spring washer 8	8	Stainless steel
11	Nuts M8	8	Stainless steel
12	Clamps	2	
13	Bolts M8×20	4	Stainless steel