

## CDMA800 & GSM900/1800 & UMTS / WIFI Combiner

**Model : PW-DUP-8022-E**

1、 Part Number: PW-DUP-8022 ver E

2、 Name: Dual-band Combiner

	<b>CH1</b>	<b>CH2</b>
<b>Freq. Range (MHz)</b>	800-2200	2400~2500
<b>Band width (MHz)</b>	1400	100
<b>Insertion loss (dB)</b>	≤0.3	≤0.6
<b>Ripple (dB)</b>	≤0.2	≤0.3
<b>Stop Attenuation (dB)</b>	≥90@CH2	≥90 @CH1
<b>Isolation (dB)</b>	≥90@CH2	≥90 @CH1
<b>Return loss (dB)</b>	≥ 20	
<b>Impedance (Ω)</b>	50	
<b>PIM (dBc)</b>	≤-140@+43dBm×2	
<b>Connector</b>	N-F	
<b>Power (W)</b>	100	
<b>Temp. (□)</b>	-25 to +65	
<b>Dimension (mm)</b>	178 × 84 × 22	
<b>Weight (kg)</b>	1.00	

3、 Dimension:

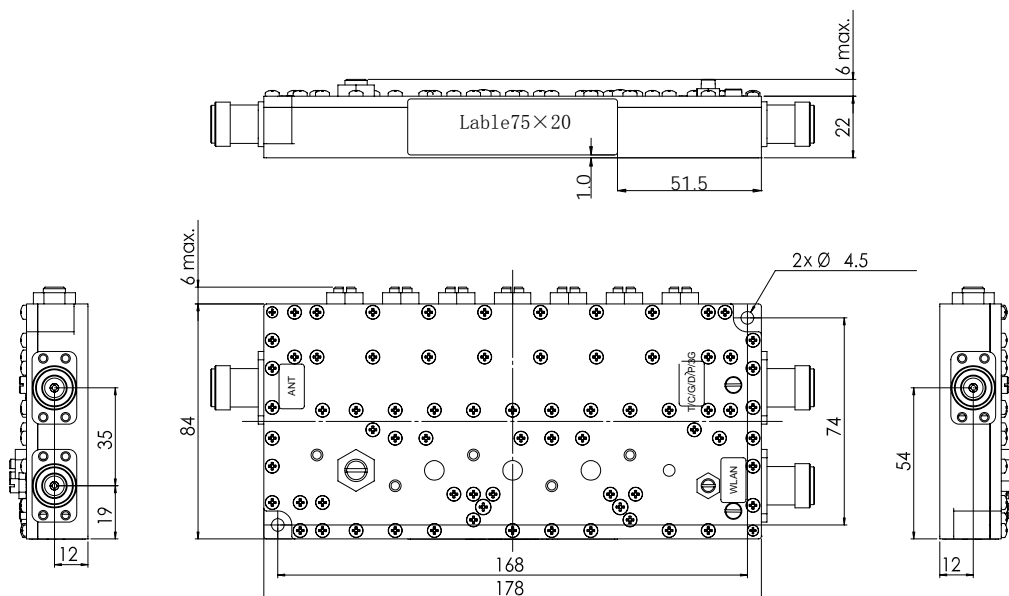

Rejection / Guard Band Graph at 824~960Mhz and 1710~2170 Mhz

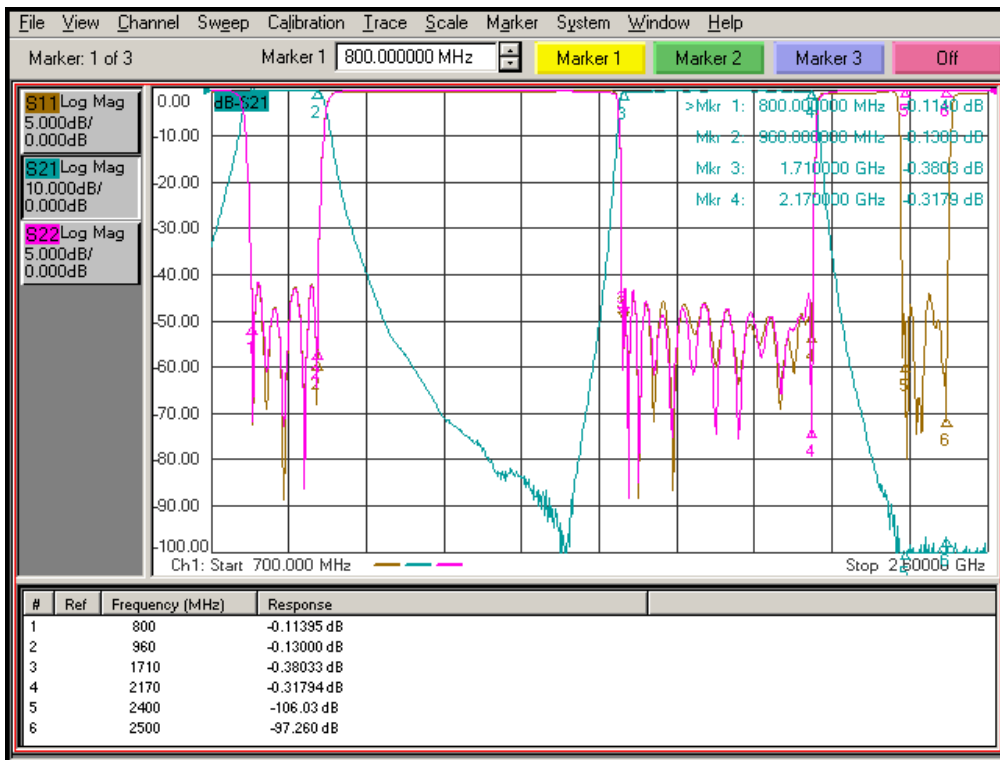

Rejection / Guard Band Graph at 2400-2500Mhz

