

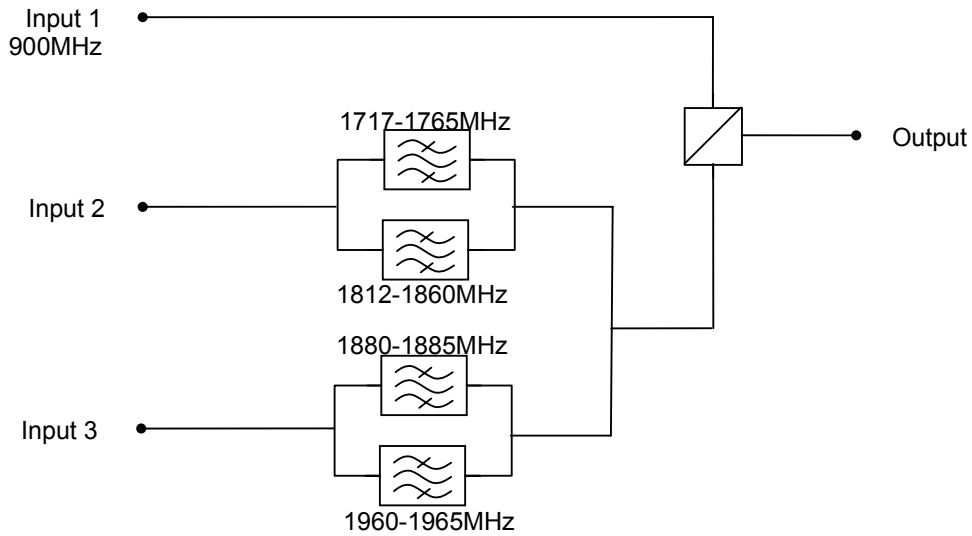

### Type 2 Combiner



Specification	
Power	100W
Insertion Loss	900MHz : 0.3dB Typically 1800MHz : 1.7dB Typically
Rejection	Input 1 / Input 2 & 3 >50dB Input 2 & Input 3 >65dB
VSWR	1.2:1
Inter-modulation	-150dBc
Temperature Range	-20 to +55 Degrees Centigrade
Impedance	50 Ohms
Connectors	7/16 DIN Female
Rack Mount	2U
Wall Mount	300mm x 300mm x 200mm